

HRW

Wide-Rail LM Guide Model HRW

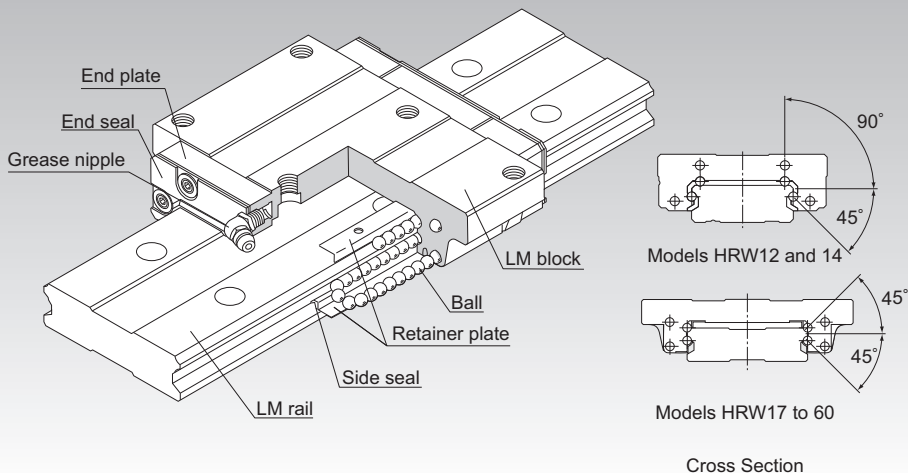

Selection Criteria **A1-10**

Design Highlights **A1-480**

Options **A1-505**

Model No. **A1-575**

Handling Precautions **A1-581**

Accessories for Lubrication **A24-1**

Mounting Procedure **B1-89**

Equivalent Moment Factor **A1-43**

Rated Loads in All Directions **A1-61**

Equivalent Factor in Each Direction **A1-63**

Radial Clearance **A1-74**

Accuracy Standards **A1-79**

Shoulder Height of the Mounting Base and the Corner Radius **A1-493**

Reference Error Tolerance for the Mounting Surface **A1-497**

Dimensions of Each Model with Options Attached **A1-519**

Structure and Features

Balls roll in four rows of raceways precision-ground on an LM rail and an LM block, and end plates incorporated in the LM block allow the balls to circulate. Since retainer plates hold the balls, they will not fall out even if the LM block is removed from the LM rail (except models HRW 12 and 14LR).

Each row of balls is placed at a contact angle of 45° so that the load ratings applied to the LM block are uniform in the four directions (radial, reverse-radial, and lateral directions), enabling the LM Guide to be used in all orientations. In addition, the LM block can receive a well-balanced preload, increasing the rigidity in the four directions while maintaining a constantly low friction coefficient. The LM rail is wide and has a low center of gravity with a low overall height, so it can be used as a single axis in locations where space is limited or where high rigidity is required due to moment loads.

Compact with Large Load Capacity

Because of the large number of load-bearing balls, this model is highly rigid in all directions. The LM rail is wide and sufficient to receive a moment load even in a single rail configuration.

Additionally, since the secondary cross-sectional moment of inertia of the LM rail is large, the rigidity in the lateral directions is also high. Accordingly, it does not need reinforcement such as a side support.

Self-Adjustment Capability

The self-adjustment capability of the front-to-front configuration of THK's unique circular-arc grooves (DF set) enables mounting error to be absorbed even under a preload, thus achieving highly accurate and smooth linear motion.

Types and Features

Model HRW-CA

The flange of the LM block has tapped holes. It can be mounted from the top or the bottom.

Dimensional Table⇒ [A1-246](#)

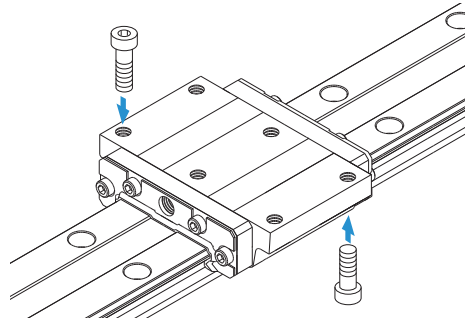

Model HRW-CR

Models HRW17/21CR have four tapped holes in the LM block. Models HRW27/35/50CR have six tapped holes in the LM block.

Dimensional Table⇒ [A1-248](#)

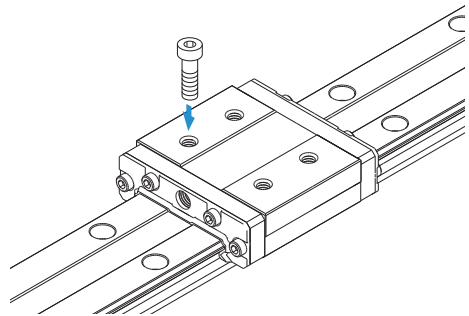

Miniature Model HRW-LRM

The LM block has tapped holes.

Dimensional Table⇒ [A1-248](#)

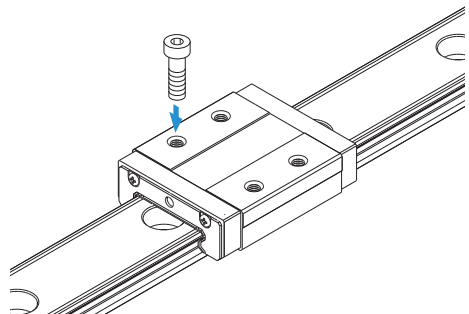

Models HRW-CA and HRW-CAM

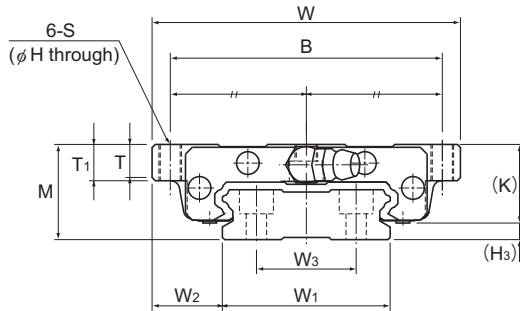

Model No.	Outer dimensions			LM block dimensions											Grease nipple	H ₃
	Height	Width	Length	B	C	H	S	L ₁	T	T ₁	K	N	E			
	M	W	L	B	C	H	S	L ₁	T	T ₁	K	N	E		H ₃	
HRW 17CA HRW 17CAM	17	60	50.8	53	26	3.3	M4	33.6	5.5	6	14.5	4	2	PB107	2.5	
HRW 21CA HRW 21CAM	21	68	58.8	60	29	4.4	M5	40	7.3	8	18	4.5	12	B-M6F	3	
HRW 27CA HRW 27CAM	27	80	72.8	70	40	5.3	M6	51.8	9.5	10	24	6	12	B-M6F	3	
HRW 35CA HRW 35CAM	35	120	106.6	107	60	6.8	M8	77.6	13	14	31	8	12	B-M6F	4	
HRW 50CA	50	162	140.5	144	80	8.6	M10	103.5	16.5	18	46.6	14	16	B-PT1/8	3.4	
HRW 60CA	60	200	158.9	180	80	10.5	M12	117.5	23.5	25	53.5	15	16	B-PT1/8	6.5	

Model number coding

HRW35 CA 2 UU C1 M +1000L P T M

Model number

Type of LM block

Contamination protection accessory symbol

Stainless steel LM block

LM rail length (in mm)

Symbol for LM rail jointed use

Stainless steel LM rail

No. of LM blocks used on the same rail

Radial clearance symbol
Normal (No symbol)
Light preload (C1)
Medium preload (C0)

Accuracy symbol
Normal grade (No Symbol)/High accuracy grade (H)
Precision grade (P)/Super precision grade (SP)
Ultra precision grade (UP)

Note) See contamination protection accessories on **A1-545**. See **A1-74** for radial clearance symbol. See **A1-79** for accuracy symbol.

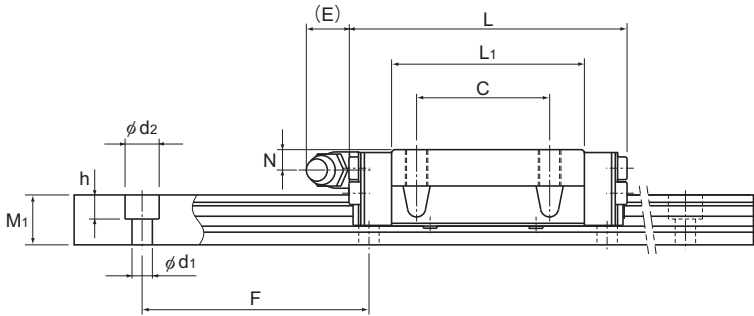

Unit: mm

LM rail dimensions								Basic load rating		Static permissible moment kN·m*						Mass	
Width W_1 ± 0.05	W_2	W_3	Height M_1	Pitch F	Pitch $d_1 \times d_2 \times h$	Length* Max	C	C_0	M_A		M_B		M_C		LM block kg	LM rail kg/m	
									1 block	Double blocks	1 block	Double blocks	1 block				
33	13.5	18	9	40	4.5×7.5×5.3	1900 (800)	5.53	9.1	0.0464	0.272	0.0464	0.272	0.144	0.15	2.1		
37	15.5	22	11	50	4.5×7.5×5.3	3000 (1000)	8.02	12.9	0.0784	0.445	0.0784	0.445	0.219	0.25	2.9		
42	19	24	15	60	4.5×7.5×5.3	3000 (1200)	14.2	21.6	0.166	0.923	0.166	0.923	0.423	0.5	4.3		
69	25.5	40	19	80	7×11×9	3000 (2120)	33.8	48.6	0.559	3.03	0.559	3.03	1.59	1.4	9.9		
90	36	60	24	80	9×14×12	3000	62.4	86.3	1.32	7.08	1.32	7.08	3.67	4	14.6		
120	40	80	31	105	11×17.5×14	3000	80.3	109	1.88	10.1	1.88	10.1	6.17	5.7	27.8		

Note) The maximum length under "Length*" indicates the standard maximum length of an LM rail. (See **A1-250**)

Static permissible moment* 1 block: the static permissible moment with one LM block

Double blocks: static permissible moment when two LM blocks are in close contact with each other
 Total block length L : The total block length L shown in the table is the length with the dust proof parts, code UU or SS.
 If other contamination protection accessories or lubricant equipment are installed, the total block length will increase.
 (See **A1-519** or **A1-541**)

The M in the model number symbol indicates that the LM block, LM rail and balls are made of stainless steel.
 The stainless steel provides excellent corrosion and environmental resistance.

Models HRW-CR, HRW-CRM, and HRW-LRM

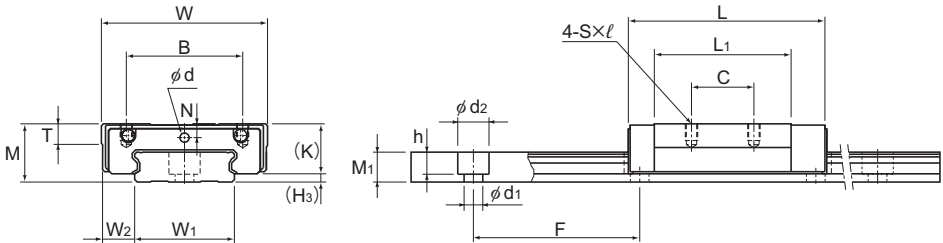

Models HRW12 and 14LRM

Model No.	Outer dimensions			LM block dimensions										Grease nipple	H ₃
	Height	Width	Length	B	C	S × ℓ	L ₁	T	K	N	E	Lubrication hole			
	M	W	L	B	C	S × ℓ	L ₁	T	K	N	E	d			
HRW 12LRM	12	30	37	21	12	M3 × 3.5	27	4	10	2.8	—	2.2	—	2	
HRW 14LRM	14	40	45.5	28	15	M3 × 4	32.9	5	12	3.3	—	2.2	—	2	
HRW 17CR HRW 17CRM	17	50	50.8	29	15	M4 × 5	33.6	6	14.5	4	2	—	PB107	2.5	
HRW 21CR HRW 21CRM	21	54	58.8	31	19	M5 × 6	40	8	18	4.5	12	—	B-M6F	3	
HRW 27CR HRW 27CRM	27	62	72.8	46	32	M6 × 6	51.8	10	24	6	12	—	B-M6F	3	
HRW 35CR HRW 35CRM	35	100	106.6	76	50	M8 × 8	77.6	14	31	8	12	—	B-M6F	4	
HRW 50 CR	50	130	140.5	100	65	M10 × 15	103.5	18	46.6	14	16	—	B-PT1/8	3.4	

Model number coding

HRW27 CR 2 UU C1 M +820L P T M

Model number

Type of LM block

Contamination protection accessory symbol

Stainless steel LM block

LM rail length (in mm)

Symbol for LM rail jointed use

Stainless steel LM rail

No. of LM blocks used on the same rail

Radial clearance symbol
Normal (No symbol)
Light preload (C1)
Medium preload (C0)

Accuracy symbol
Normal grade (No Symbol)/High accuracy grade (H)
Precision grade (P)/Super precision grade (SP)
Ultra precision grade (UP)

Note) See contamination protection accessories on [A1-545](#). See [A1-74](#) for radial clearance symbol. See [A1-79](#) for accuracy symbol.

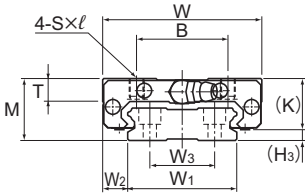

Models HRW17 and 21CR/CRM

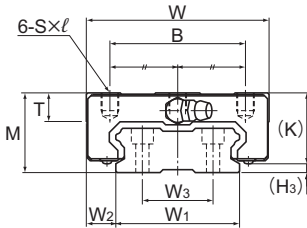

Models HRW27, 35CR/CRM, and HRW50CR

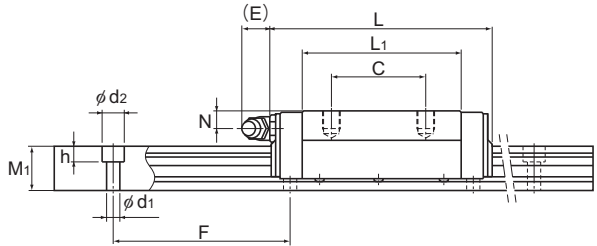

Unit: mm

LM rail dimensions							Basic load rating		Static permissible moment kN·m*					Mass	
Width W ₁ ±0.05	W ₂	W ₃	Height/Pitch		Length* Max	C kN	C ₀ kN	M _a		M _b		M _c	LM block kg	LM rail kg/m	
			M ₁	F				d ₁ × d ₂ × h	1 block	Double blocks	1 block	Double blocks			1 block
18	6	—	6.5	40	4.5 × 8 × 4.5 (1000)	3.29	7.16	0.0262	0.138	0.013	0.069	0.051	0.045	0.79	
24	8	—	7.2	40	4.5 × 7.5 × 5.3 (1430)	5.38	11.4	0.0499	0.273	0.025	0.137	0.112	0.08	1.2	
33	8.5	18	9	40	4.5 × 7.5 × 5.3 1900 (800)	5.53	9.1	0.0464	0.272	0.0464	0.272	0.144	0.12	2.1	
37	8.5	22	11	50	4.5 × 7.5 × 5.3 3000 (1000)	8.02	12.9	0.0784	0.445	0.0784	0.445	0.219	0.19	2.9	
42	10	24	15	60	4.5 × 7.5 × 5.3 3000 (1200)	14.2	21.6	0.166	0.923	0.166	0.923	0.423	0.37	4.3	
69	15.5	40	19	80	7 × 11 × 9 3000 (2120)	33.8	48.6	0.559	3.03	0.559	3.03	1.59	1.2	9.9	
90	20	60	24	80	9 × 14 × 12 3000	62.4	86.3	1.32	7.08	1.32	7.08	3.67	3.2	14.6	

Note1) The maximum length under "Length*" indicates the standard maximum length of an LM rail. (See **A1-250**.)

Static permissible moment* 1 block: the static permissible moment with one LM block

Double blocks: static permissible moment when two LM blocks are in close contact with each other

Total block length L : The total block length L shown in the table is the length with the dust proof parts, code UU or SS. If other contamination protection accessories or lubricant equipment are installed, the total block length will increase.

(See **A1-519** or **A1-541**)

The M in the model number symbol indicates that the LM block, LM rail and balls are made of stainless steel.

The stainless steel provides excellent corrosion and environmental resistance.

Note2) Basic load ratings in the table are those for loads in the radial direction. Use Table 7 on **A1-61** to calculate the load rating for loads in the reverse-radial direction or lateral direction for HRW12 and 14, as those values are different.

Standard Lengths and Maximum Lengths of LM Rails

Table 1 shows the standard and maximum lengths of the HRW model rail. If a rail length longer than the listed max length is required, rails may be jointed to meet the overall length. Contact THK for details.

For special rail lengths, it is recommended to use a value corresponding to the G and g dimensions from the table. As the G and g dimensions increase, this portion becomes less stable, and the accuracy performance is severely impacted.

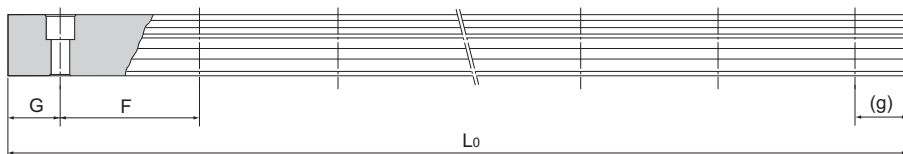

Table 1: Standard Lengths and Maximum Lengths of LM Rails for Model HRW

Unit: mm

Model No.	HRW 12	HRW 14	HRW 17	HRW 21	HRW 27	HRW 35	HRW 50	HRW 60
LM rail standard lengths (L ₀)	70	70	110	130	160	280	280	570
	110	110	190	230	280	440	440	885
	150	150	310	380	340	760	760	1200
	190	190	470	480	460	1000	1000	1620
	230	230	550	580	640	1240	1240	2040
	270	270		780	820	1560	1640	2460
	310	310					2040	
	390	390						
	470	470						
		550	670					
Standard pitch F	40	40	40	50	60	80	80	105
G, g	15	15	15	15	20	20	20	22.5
Max length	(1000)	(1430)	1900 (800)	3000 (1000)	3000 (1200)	3000 (2120)	3000	3000

Note1) The maximum length varies with accuracy grades. Contact THK for details.

Note2) If jointed rails are not allowed and a greater length than the maximum values above is required, contact THK.

Note3) The figures in the parentheses indicate the maximum lengths of stainless steel made models.

Preventing the LM Block from Falling off of the LM Rail

In miniature model HRW, the balls fall out if the LM block comes off the LM rail.

For this reason, LM Guide assemblies are delivered with a part which prevents the LM block from coming off the rail. If you remove this part when using the product, please take precautions to avoid overrunning the blocks off of the rail.

